

# 0402 LMCI Inductor Material Composition

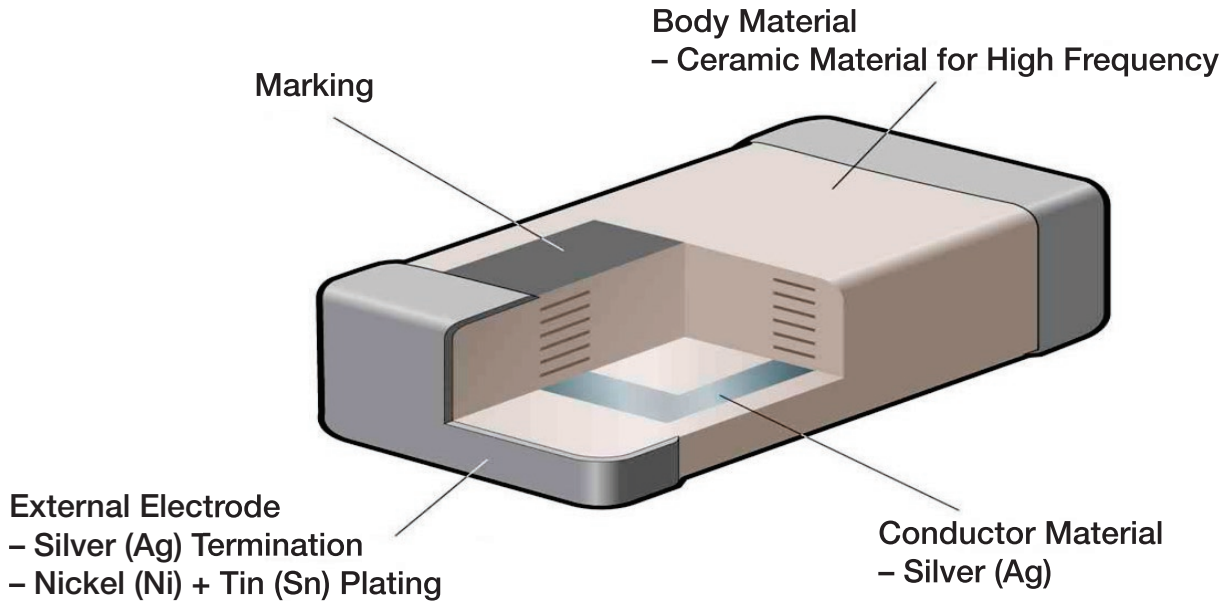

\*The color of the inductor shown is different from actual product.

This statement pertains to the following directive: 2002/95/EC of the European Parliament and of the Council of the European Union of January 27, 2003 on the restriction of the use of certain hazardous substances in electrical and electronic equipment regarding Article 4 and its subsequent annex on the exemption of lead in glass. No. 5 in the annex states that lead in glass of cathode ray tubes, electronic components and fluorescent tubes are exempt from RoHS requirements. Therefore any lead oxide in glass of any size inductor is exempt and all inductors meet RoHS requirements.

PART	Material	Substance	CAS No.	Mass (mg)	Wt. %
BODY	Glass	Silicon Oxide (SiO <sub>2</sub> )	14808-60-7	0.2103	22.102%
	Glass	Boron Oxide (B <sub>2</sub> O <sub>3</sub> )	1303-86-2	0.0486	5.108%
	Glass	Potassium Oxide(K <sub>2</sub> O)	12136-45-7	0.0108	1.135%
	Filler	Aluminium Oxide (Al <sub>2</sub> O <sub>3</sub> )	1344-28-1	0.2206	23.184%
CONDUCTOR	Silver	Silver (Ag)	7440-22-4	0.2153	22.627%
TERMINAL CONDUCTOR	Silver	Silver (Ag)	7440-22-4	0.1611	16.931%
	Glass	Lead Oxide (PbO)	1317-36-8	0.0122	1.282%
	Glass	Silicon Oxide (SiO <sub>2</sub> )	14808-60-7	0.0034	0.357%
	Glass	Boron Oxide (B <sub>2</sub> O <sub>3</sub> )	1303-86-2	0.0073	0.767%
	Cupric Oxide	Cupric Oxide (CuO)	1317-38-0	0.0015	0.158%
PLATING	Nickel	Nickel (Ni)	7440-02-0	0.0181	1.902%
	Tin	100% matte Tin (Sn)	7440-31-5	0.0423	4.446%
TOTAL				0.9515	100.00%

# 0603 LMCI Inductor Material Composition

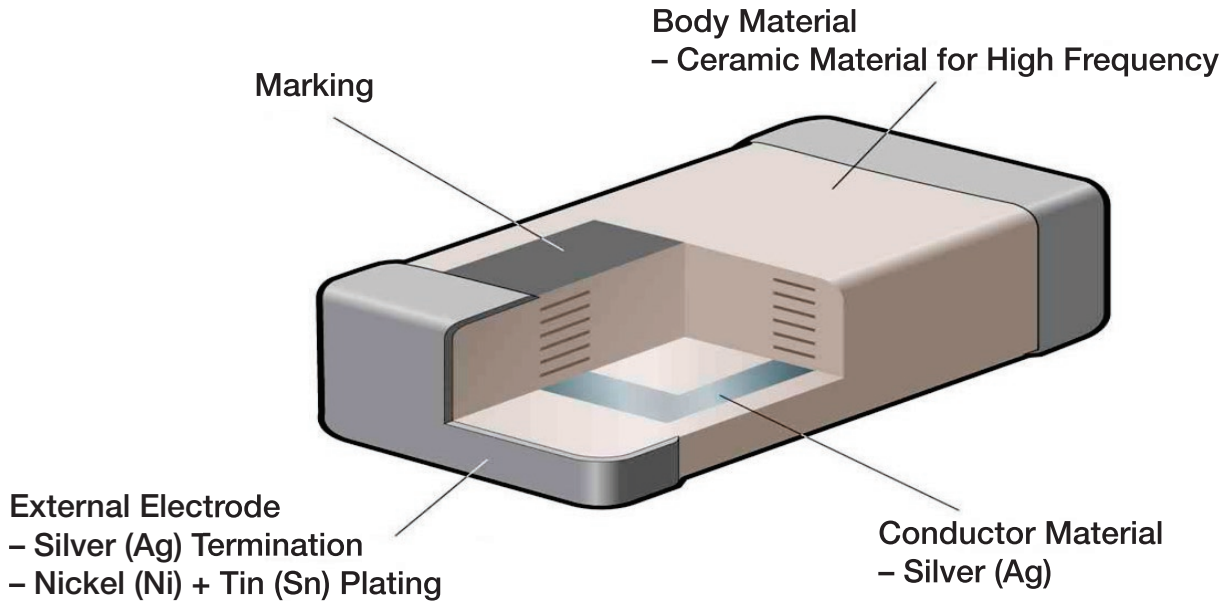

\*The color of the inductor shown is different from actual product.

This statement pertains to the following directive: 2002/95/EC of the European Parliament and of the Council of the European Union of January 27, 2003 on the restriction of the use of certain hazardous substances in electrical and electronic equipment regarding Article 4 and its subsequent annex on the exemption of lead in glass. No. 5 in the annex states that lead in glass of cathode ray tubes, electronic components and fluorescent tubes are exempt from RoHS requirements. Therefore any lead oxide in glass of any size inductor is exempt and all inductors meet RoHS requirements.

PART	Material	Substance	CAS No.	Mass (mg)	Wt. %
BODY	Glass	Silicon Oxide (SiO <sub>2</sub> )	14808-60-7	1.0125	31.063%
	Glass	Boron Oxide (B <sub>2</sub> O <sub>3</sub> )	1303-86-2	0.2338	7.173%
	Glass	Potassium Oxide (K <sub>2</sub> O)	12136-45-7	0.0521	1.598%
	Filler	Aluminium Oxide (Al <sub>2</sub> O <sub>3</sub> )	1344-28-1	1.0624	32.594%
CONDUCTOR	Silver	Silver (Ag)	7440-22-4	0.2668	8.185%
TERMINAL CONDUCTOR	Silver	Silver (Ag)	7440-22-4	0.4138	12.695%
	Glass	Lead Oxide (PbO)	1317-36-8	0.0314	0.963%
	Glass	Silicon Oxide (SiO <sub>2</sub> )	14808-60-7	0.0088	0.270%
	Glass	Boron Oxide (B <sub>2</sub> O <sub>3</sub> )	1303-86-2	0.0188	0.577%
	Cupric Oxide	Cupric Oxide (CuO)	1317-38-0	0.0039	0.120%
PLATING	Nickel	Nickel (Ni)	7440-02-0	0.0465	1.427%
	Tin	100% matte Tin (Sn)	7440-31-5	0.1087	3.335%
TOTAL				3.2595	100.00%

# 0603 MLF Inductor Material Composition

Body: Ferrite Material

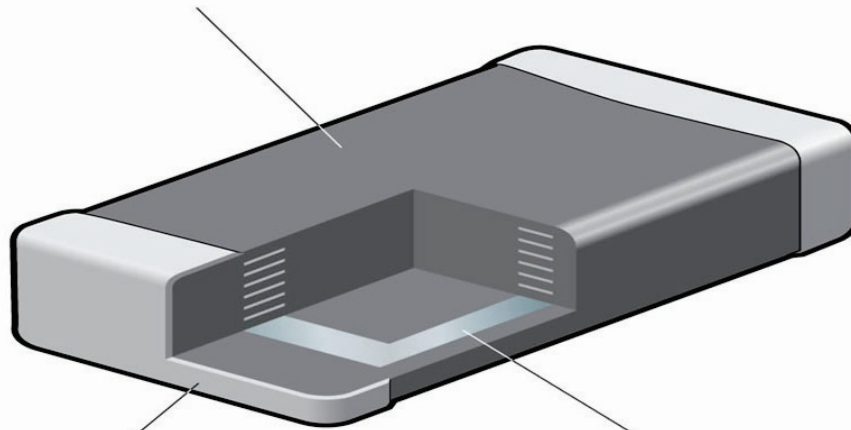

External Electrode  
– Silver (Ag) Termination  
– Nickel (Ni) + Tin (Sn) Plating

Internal Conductor :  
Silver (Ag)

\*The color of the inductor shown is different from actual product.

This statement pertains to the following directive: 2002/95/EC of the European Parliament and of the Council of the European Union of January 27, 2003 on the restriction of the use of certain hazardous substances in electrical and electronic equipment regarding Article 4 and its subsequent annex on the exemption of lead in glass. No. 5 in the annex states that lead in glass of cathode ray tubes, electronic components and fluorescent tubes are exempt from RoHS requirements. Therefore any lead oxide in glass of any size inductor is exempt and all inductors meet RoHS requirements.

PART	Material	Substance	CAS No.	Mass (mg)	Wt. %
BODY	Ferrite	Nickel Oxide (NiO)	1319-99-1	0.5560	10.059%
	Ferrite	Zinc Oxide (ZnFe <sub>2</sub> O <sub>4</sub> )	1324-14-2	0.6410	11.597%
	Ferrite	Copper Oxide (CuO)	1317-38-0	0.3090	5.590%
	Ferrite	Ferrite Oxide (Fe <sub>2</sub> O <sub>3</sub> )	1309-37-1	3.0120	54.493%
	Glass	Bismuth Oxide (Bi <sub>2</sub> O <sub>3</sub> )	1317-36-8	0.0811	1.467%
	Glass	Silicon Oxide (SiO <sub>2</sub> )	14808-60-7	0.0290	0.525%
	Glass	Zinc Oxide (ZnO)	1314-13-2	0.0057	0.103%
CONDUCTOR	Silver	Silver (Ag)	7440-22-4	0.2670	4.831%
TERMINAL CONDUCTOR	Silver	Silver (Ag)	7440-22-4	0.4140	7.490%
	Glass	Lead Oxide (PbO)	1317-36-8	0.0289	0.523%
	Glass	Silicon Oxide (SiO <sub>2</sub> )	14808-60-7	0.0081	0.147%
	Glass	Boron Oxide (B <sub>2</sub> O <sub>3</sub> )	1303-86-2	0.0174	0.314%
	Cupric Oxide	Cupric Oxide (CuO)	1317-38-0	0.0035	0.063%
PLATING	Nickel	Nickel (Ni)	7440-02-0	0.0460	0.832%
	Tin	100% matte Tin (Sn)	7440-31-5	0.1087	1.967%
TOTAL				5.5273	100.00%

# 0805 MLF Inductor Material Composition

Body: Ferrite Material

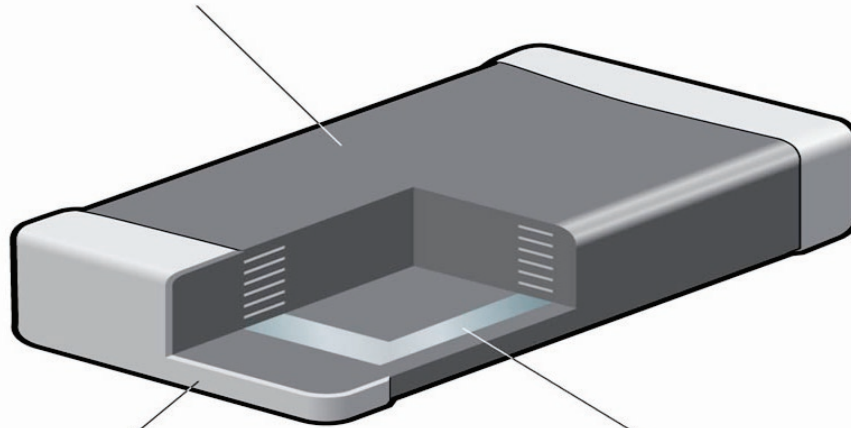

External Electrode  
 – Silver (Ag) Termination  
 – Nickel (Ni) + Tin (Sn) Plating

Internal Conductor :  
 Silver (Ag)

\*The color of the inductor shown is different from actual product.

This statement pertains to the following directive: 2002/95/EC of the European Parliament and of the Council of the European Union of January 27, 2003 on the restriction of the use of certain hazardous substances in electrical and electronic equipment regarding Article 4 and its subsequent annex on the exemption of lead in glass. No. 5 in the annex states that lead in glass of cathode ray tubes, electronic components and fluorescent tubes are exempt from RoHS requirements. Therefore any lead oxide in glass of any size inductor is exempt and all inductors meet RoHS requirements.

PART	Material	Substance	CAS No.	Mass (mg)	Wt. %
BODY	Ferrite	Nickel Oxide(NiO)	1319-99-1	1.2348	9.815%
	Ferrite	Zinc Oxide (ZnFe <sub>2</sub> O <sub>4</sub> )	1324-14-2	1.4235	11.315%
	Ferrite	Copper Oxide (CuO)	1317-38-0	0.6862	5.455%
	Ferrite	Ferrite Oxide(Fe <sub>2</sub> O <sub>3</sub> )	1309-37-1	6.6891	53.170%
	Glass	Bismuth Oxide (Bi <sub>2</sub> O <sub>3</sub> )	1317-36-8	0.1801	1.432%
	Glass	Silicon Oxide (SiO <sub>2</sub> )	14808-60-7	0.0644	0.512%
	Glass	Zinc Oxide (ZnO)	1314-13-2	0.0127	0.101%
CONDUCTOR	Silver	Silver (Ag)	7440-22-4	0.4774	3.795%
TERMINAL CONDUCTOR	Silver	Silver (Ag)	7440-22-4	1.4750	11.724%
	Glass	Lead Oxide (PbO)	1317-36-8	0.0536	0.426%
	Glass	Silicon Oxide (SiO <sub>2</sub> )	14808-60-7	0.0150	0.119%
	Glass	Boron Oxide (B <sub>2</sub> O <sub>3</sub> )	1303-86-2	0.0322	0.256%
	Cupric Oxide	Cupric Oxide (CuO)	1317-38-0	0.0064	0.051%
PLATING	Nickel	Nickel (Ni)	7440-02-0	0.0689	0.548%
	Tin	100% matte Tin (Sn)	7440-31-5	0.1613	1.282%
TOTAL				12.5806	100.00%