

# Rectangular Thin Film Chip Resistors

## Features

These Thin Film Chip Resistors are designed for high precision, stability and reliability. Available in 0201 thru 2512 sizes, having a TCR of either  $\pm 25\text{PPM}/^\circ\text{C}$ ,  $\pm 50\text{PPM}/^\circ\text{C}$  or  $\pm 100\text{PPM}/^\circ\text{C}$ . Suitable for flow and reflow soldering.

## Dimensions

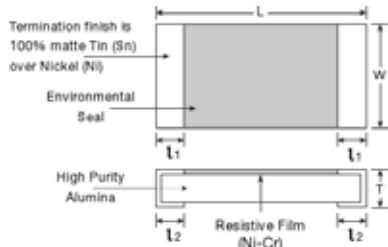

Unit: inches (mm)

	L	W	T	t <sub>1</sub>	t <sub>2</sub>
TFCR0201	0.024 ± 0.002 (0.6 ± 0.05)	0.012 ± 0.001 (0.3 ± 0.02)	0.010 ± 0.002 (0.25 ± 0.05)	0.006 ± 0.002 (0.15 ± 0.05)	0.006 ± 0.002 (0.15 ± 0.05)
TFCR0402	0.040 ± 0.002 (1.0 ± 0.05)	0.020 ± 0.002 (0.5 ± 0.05)	0.014 ± 0.002 (0.35 ± 0.05)	0.008 ± 0.004 (0.2 ± 0.01)	0.008 ± 0.004 (0.2 ± 0.01)
TFCR0603	0.063 ± 0.008 (1.6 ± 0.2)	0.031 ± 0.008 (0.8 ± 0.2)	0.014 ± 0.004 (0.45 ± 0.10)	0.010 ± 0.006 (0.25 ± 0.15)	0.010 ± 0.006 (0.25 ± 0.15)
TFCR0805	0.079 ± 0.008 (2.0 ± 0.2)	0.050 ± 0.008 (1.25 ± 0.20)	0.018 ± 0.006 (0.45 ± 0.15)	0.016 ± 0.008 (0.4 ± 0.2)	0.012 ± 0.008 (0.3 ± 0.2)
TFCR1206	0.126 ± 0.008 (3.2 ± 0.2)	0.063 ± 0.008 (1.6 ± 0.2)	0.022 ± 0.006 (0.57 ± 0.15)	0.018 ± 0.008 (0.45 ± 0.2)	0.012 ± 0.008 (0.3 ± 0.2)
TFCR1210	0.126 ± 0.008 (3.2 ± 0.2)	0.098 ± 0.006 (2.50 ± 0.15)	0.022 ± 0.006 (0.56 ± 0.15)	0.018 ± 0.008 (0.45 ± 0.2)	0.012 ± 0.008 (0.3 ± 0.2)
TFCR2010	0.197 ± 0.008 (5.0 ± 0.20)	0.098 ± 0.006 (2.50 ± 0.15)	0.217 ± 0.004 (0.55 ± 0.10)	0.236 ± 0.012 (0.60 ± 0.30)	0.02 ± 0.010 (0.50 ± 0.25)
TFCR2512	0.248 ± 0.008 (6.30 ± 0.20)	0.122 ± 0.006 (3.10 ± 0.15)	0.217 ± 0.004 (0.55 ± 0.10)	0.236 ± 0.012 (0.60 ± 0.30)	0.02 ± 0.010 (0.50 ± 0.25)

## Specifications

Series	Rated Power at 70°C	Maximum Working Voltage	*Maximum Overload Voltage	Operating Temperature Range	Resistance Range
TFCR0201-20W	0.05W	$\sqrt{PR}$ or 15V whichever is less	30V	-55°C ~ 150°C	50Ω ~ 33KΩ
TFCR0402-16W	0.063W	$\sqrt{PR}$ or 25V whichever is less	75V	-55°C ~ 150°C	10Ω ~ 255KΩ
TFCR0603-16W	0.063W	$\sqrt{PR}$ or 75V whichever is less	150V	-55°C ~ 150°C	4.7Ω ~ 1 Meg Ω
TFCR0603-10W	0.10W	$\sqrt{PR}$ or 75V whichever is less	150V	-55°C ~ 150°C	4.7Ω ~ 1 Meg Ω
TFCR0805-10W	0.10W	$\sqrt{PR}$ or 100V whichever is less	200V	-55°C ~ 150°C	4.7Ω ~ 2 Meg Ω
TFCR0805-8W	0.125W	$\sqrt{PR}$ or 100V whichever is less	200V	-55°C ~ 150°C	4.7Ω ~ 2 Meg Ω
TFCR1206-8W	0.125W	$\sqrt{PR}$ or 150V whichever is less	300V	-55°C ~ 150°C	4.7Ω ~ 2.5 Meg Ω
TFCR1206-4W	0.25W	$\sqrt{PR}$ or 150V whichever is less	300V	-55°C ~ 150°C	4.7Ω ~ 2.5 Meg Ω
TFCR1210-4W	0.25W	$\sqrt{PR}$ or 150V whichever is less	300V	-55°C ~ 150°C	4.7Ω ~ 1 Meg Ω
TFCR1210-2W	0.5W	$\sqrt{PR}$ or 150V whichever is less	300V	-55°C ~ 150°C	4.7Ω ~ 1 Meg Ω
TFCR2010-2W	0.5W	$\sqrt{PR}$ or 150V whichever is less	300V	-55°C ~ 150°C	4.7Ω ~ 1 Meg Ω
TFCR2512-2W	0.5W	$\sqrt{PR}$ or 150V whichever is less	300V	-55°C ~ 150°C	4.7Ω ~ 1 Meg Ω

NOTE: \* Overload Voltage=2.5\* $\sqrt{PR}$  or Max. overload voltage listed above, whichever is lower.

Markings on Thin Film Chip Resistors may have an internal lot identification code or the E-24 (5%) or E-96 (1%) marking code. If value identification is required, please consult your sales representative for availability. Values available in the E-24 Series that are crossover values (same value for 1% and 5%) will typically be marked with a 3-digit E-24 Series marking code.

\* For 0201 case size: TCR is 50ppm for values above 5K Ω

## How To Order

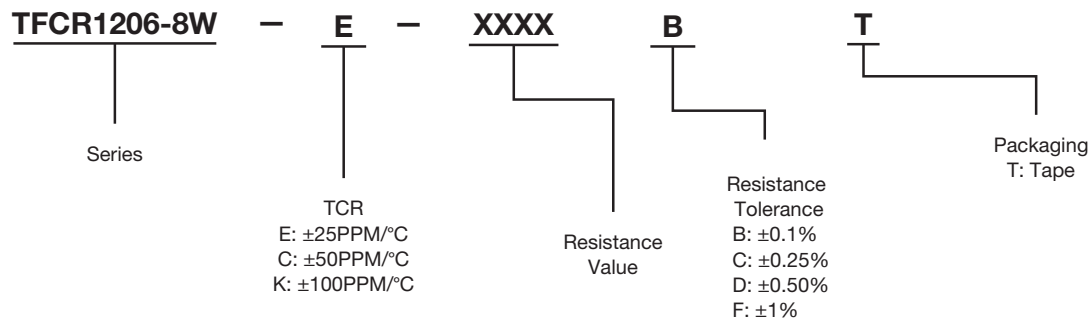

All components in this section are RoHS compliant per the EU directives and definitions.

5900 Shepherd Mountain Cove • Austin, TX 78730  
Phone: 512 / 794-0081 • Fax: 512 / 794-0087 • Toll Free: 800 / 950-8365  
e-mail: sales@venkel.com • www.venkel.com



VENKEL LTD.

# Characteristics

DERATING CURVE

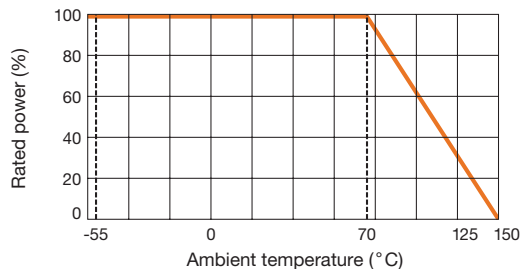

Description	Requirements	Test method JIS C 5202
<b>Resistance Value</b>	Within specified tolerance	
<b>Temperature Coefficient of Resistance (T.C.R.)</b>	E: Within $\pm 25\text{PPM}/^\circ\text{C}$ C: Within $\pm 50\text{PPM}/^\circ\text{C}$ K: Within $\pm 100\text{PPM}/^\circ\text{C}$	Measuring temperature +25/ + 125°C
<b>Short-time Overload</b>	Within $\pm (0.5\% + 0.05\Omega)$ No major visible damage	2.5 times rated voltage 5 seconds
<b>Insulation Resistance</b>	At least 1,000 Meg $\Omega$	100V 1 minute
<b>Withstanding Voltage</b>	Within $\pm (0.5\% + 0.05\Omega)$ no flashover, scorching or insulation breakdown	1/10: AC 150V 1 minute 1/8: AC 300V 1 minute
<b>Terminal Strength</b>	Within $\pm (0.5\% + 0.05\Omega)$ No mechanical damage	Install a sample on the board and bend the board 3/45mm for 10 seconds
<b>Solder Heat Resistance</b>	Within $\pm (0.5\% + 0.05\Omega)$ No major visible damage	Dip into 260°C solder bath for 10 seconds
<b>Solderability</b>	At least 95% of the dipping surface must be covered by new solder	235°C 2 seconds
<b>Temperature Cycle</b>	Within $\pm (0.5\% + 0.05\Omega)$ No major visible damage Markings Legible	Cycle between -55°C and + 150°C for 5 cycles
<b>Load Life in Moisture</b>	Within $\pm (0.5\% + 0.05\Omega)$ No major visible damage Markings Legible	Rated voltage 1.5 hours "ON" 0.5 hours "OFF" 40°C, 95% RH 1,000 hours
<b>Load Life</b>	Within $\pm (0.5\% + 0.05\Omega)$ No major visible damage Markings Legible	Rated voltage 1.5 hours "ON" 0.5 hours "OFF" 70°C 1,000 hours

\* NOTE: These specifications are typical and are based on standard operating conditions.

## Examples of Typical Characteristics

Temperature Coefficient of Resistance (25°C/125°C)

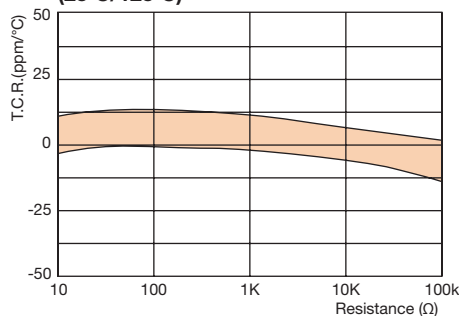

Short-time Overload

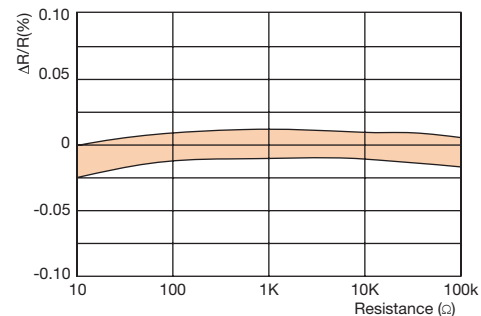

Solder Heat Resistance (260°C, 10 seconds)

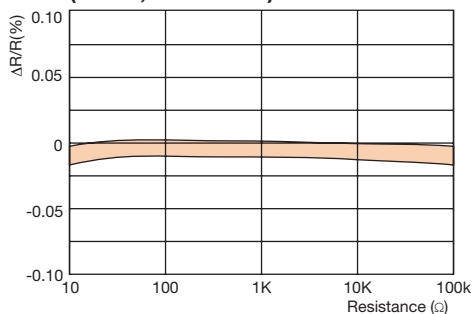

Temperature Cycle (-55°C/125°C, 5 cycles)

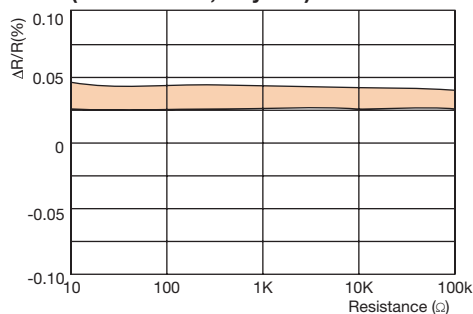

Load Life in Moisture (40°C, 90-95% RH, RCWV 1,000 hours)

